

GaAs SP3T 2.5 V High Power Switch DC - 2.5 GHz

SW-489
V1

Features

- Low Voltage Operation: 2.5 V
- Low Harmonics: -74 dBc at +34 dBm & 1 GHz
- Low Insertion Loss: 0.5 dB at 1 GHz
- High Isolation: 18.5 dB at 2 GHz
- 3 mm 12-Lead PQFN Package
- 0.5 micron GaAs PHEMT Process

Description

M/A-COM's SW-489 is a GaAs PHEMT MMIC single pole three throw (SP3T) high power switch in a low cost 3 mm 12-lead PQFN package. The SW-489 is ideally suited for applications where high power, low control voltage, low insertion loss, high isolation, small size and low cost are required.

Typical applications are for GSM and DCS handset systems that connect separate transmit and receive functions to a common antenna, as well as other handset and related applications. The SW-489 can be used in all systems operating up to 2.5 GHz requiring high power at low control voltage.

The SW-489 is fabricated using a 0.5 micron gate length GaAs PHEMT process. The process features full passivation for performance and reliability.

Ordering Information

Part Number	Package
SW-489	Bulk Packaging
SW-489TR	1000 piece reel
SW-489SMB	Sample Test Board

Note: Reference Application Note M513 for reel size information.

Absolute Maximum Ratings ^{1,2}

Parameter	Absolute Maximum
Input Power (0.5 - 2.5 GHz, 2.5 V Control)	+38 dBm
Operating Voltage	+8.5 V
Operating Temperature	-40°C to +85°C
Storage Temperature	-65°C to +150°C

1. Exceeding any one or combination of these limits may cause permanent damage to this device.
2. M/A-COM does not recommend sustained operation near these survivability limits.

Functional Schematic

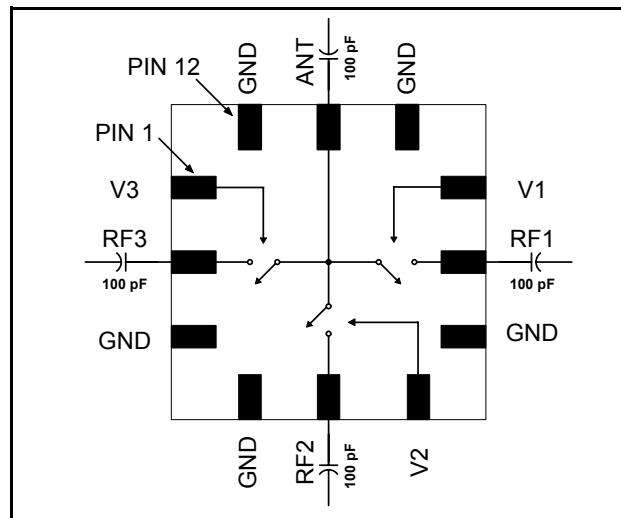

Pin Configuration

Pin No.	Pin Name	Description
1	V3	Control 3
2	RF3	RF Port 3
3	GND	RF Ground
4	GND	RF Ground
5	RF2	RF Port 2
6	V2	Control 2
7	GND	RF Ground
8	RF1	RF Port 1
9	V1	Control 1
10	GND	RF Ground
11	ANT	Antenna Port
12	GND	RF Ground
13	GND (paddle) ³	RF Ground

3. The exposed pad centered on the package bottom must be connected to RF and DC ground.

**GaAs SP3T 2.5 V High Power Switch
DC - 2.5 GHz**

**SW-489
V1**

Electrical Specifications: $T_A = 25^\circ\text{C}$, $P_{IN} = +34\text{ dBm}$, $V_C = 0 / 2.5\text{ V}$, $Z_0 = 50\ \Omega$ ⁴

Parameter	Test Conditions	Units	Min.	Typ.	Max.
Insertion Loss ⁵	DC – 1 GHz	dB	—	0.5	0.65
	1 – 2 GHz	dB	—	0.6	0.8
	2 - 2.5 GHz	dB	—	0.8	1.0
Isolation	DC – 1 GHz	dB	23	25	—
	1 – 2 GHz	dB	18	18.5	—
	2 - 2.5 GHz	dB	15	16	—
Return Loss	DC – 2.5 GHz	dB	—	20	—
P1dB	—	dBm	—	38	—
2 nd Harmonic	1 GHz, $P_{IN} = +34\text{ dBm}$	dBc	—	-74	-65
3 rd Harmonic	1 GHz, $P_{IN} = +34\text{ dBm}$	dBc	—	-72	-65
Trise, Tfall	10% to 90% RF, 90% to 10% RF	μS	—	1	—
Ton, Toff	50% control to 90% RF, and 50% control to 10% RF	μS	—	1	—
Transients	In Band	mV	—	10	—
Control Current	$ V_C = 2.5\text{ V}$	μA	—	20	80

4. For positive voltage control, external DC blocking capacitors are required on all RF ports.

5. Insertion loss can be optimized by varying the DC blocking capacitor value, e.g. 1000 pF for 100 - 500 MHz, 100 pF for 0.5 GHz - 2.5 GHz.

Truth Table ^{6,7}

V1	V2	V3	ANT - RF1	ANT - RF2	ANT - RF3
1	0	0	On	Off	Off
0	1	0	Off	On	Off
0	0	1	Off	Off	On

6. Differential voltage, $V(\text{state } 1) - V(\text{state } 0)$, must be +2.3 V minimum and less than 5.2 V.

7. 0 = 0 \pm 0.2 V, 1 = +2.5 to +5 V

Handling Procedures

Please observe the following precautions to avoid damage:

Static Sensitivity

Gallium Arsenide Integrated Circuits are sensitive to electrostatic discharge (ESD) and can be damaged by static electricity. Proper ESD control techniques should be used when handling these devices.

**GaAs SP3T 2.5 V High Power Switch
DC - 2.5 GHz**

**SW-489
V1**

Typical Performance Curves

Insertion Loss, 25°C, 100 pF

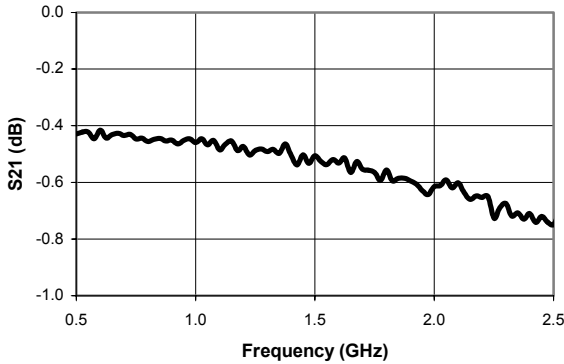

Isolation, 25°C, 100 pF

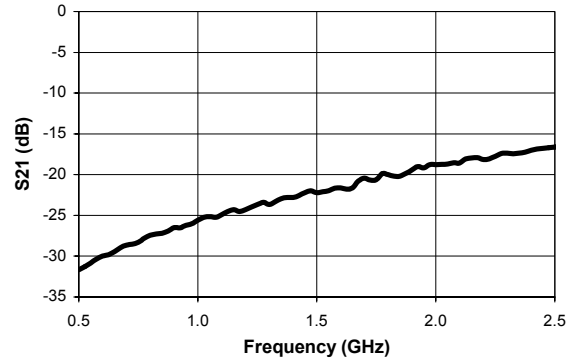

Harmonics, 25°C, 100 pF

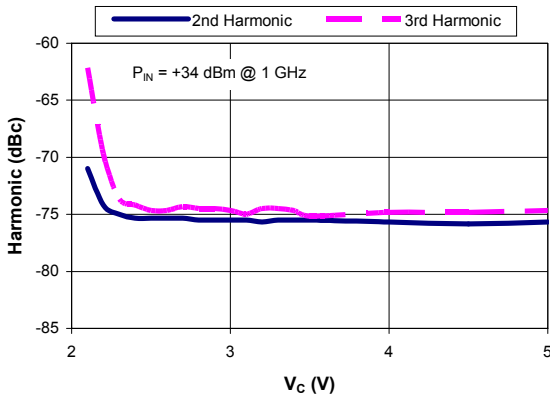

3 mm 12-Lead PQFN

